



ICEC PRICE LIST FOR  **metcalfe**<sup>TM</sup> PRODUCTS

Raising the standard of food  
preparation and bringing artistry  
back to the kitchen

# WHY BUY METCALFE SLICERS?

Metcalfe have a long and proud tradition of slicer design and manufacture in the UK. In the 1920s, Mr C. B. Metcalfe founded the first Metcalfe factory in Coventry, manufacturing meat slicers, potato peelers and chippers. Using this long history of expertise, knowledge and skill all Metcalfe slicers are designed and manufactured to provide years of perfect slicing performance to an operator on any level. With over 23 slicers in our range and numerous optional extras we can provide a perfect slicing solution to any of today's demanding food-service environments from small and medium sized cafes and restaurants all the way up to high volume supermarkets, restaurants, delis and central production kitchens.

- 1 Built in sharpening head with metal guard
- 2 Plexiglass hi-visibility safety guard (CE approved plexiglass)
- 3 Secure feet to eliminate body movement during operation
- 4 Precise cut thickness adjustment
- 5 Carriage handle on HD models
- 6 Finest quality steel alloys C45 and 100Cr6 are used in Metcalfe blades. All blades are hardened, tempered and electronically balanced. They are chrome plated to resist corrosion and rust
- 7 All Metcalfe slicers disassemble without the need of tools for easy cleaning
- 8 Blade ring-guard for safety protection
- 9 Premium aluminium alloy used providing outstanding robust construction



Rear blade deflection cover for consistent product positioning and cleaner operation. Style varies between models.



Spiked meat grip for firm control of food product. Style varies between models.



Built in sharpening head with durable aluminium cover on all models. Style varies between models.

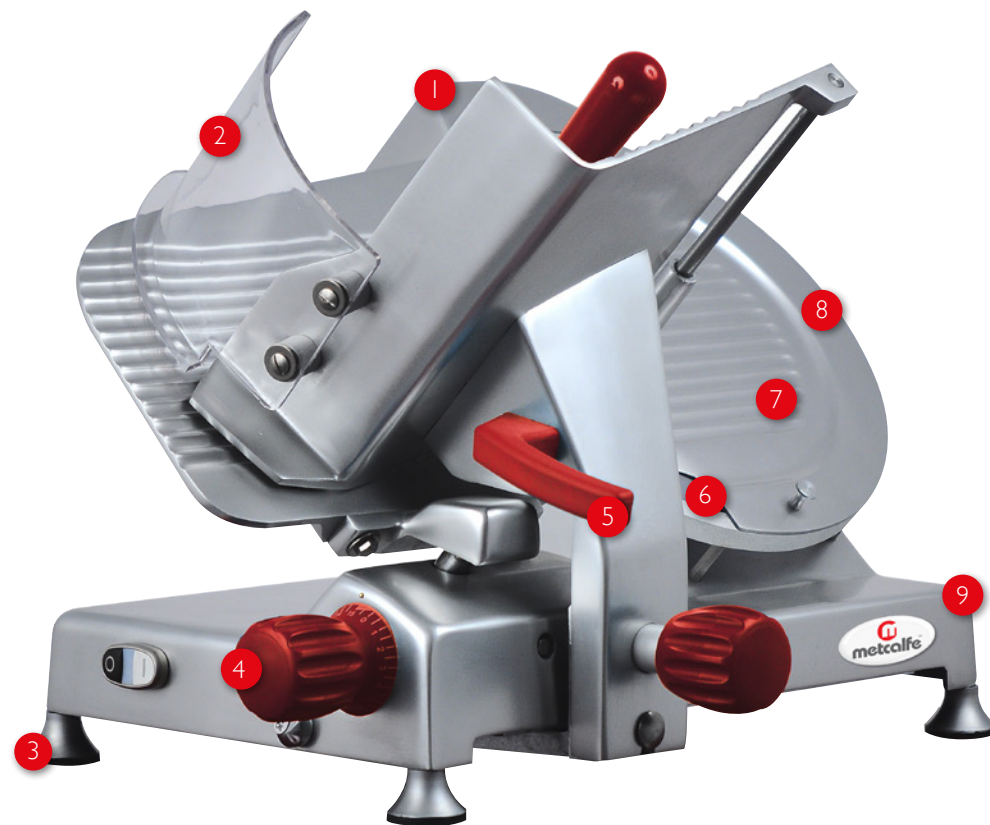

## SIMPLE LINE SLICERS

- A range of compact, light duty slicers designed for operators who only need a slicer for low volume, light duty work
- The simple line of gravity fed slicers are available with either 220mm or 250mm blades and provide excellent performance at a budget price
- Suitable for small shops, small kitchens and domestic use
- Simple but robust and functional
- Constructed entirely in aluminium and available with and without integrated sharpener
- CE approved
- Simple Line are not suitable for slicing cheese, cured meats or salami

### NSL220

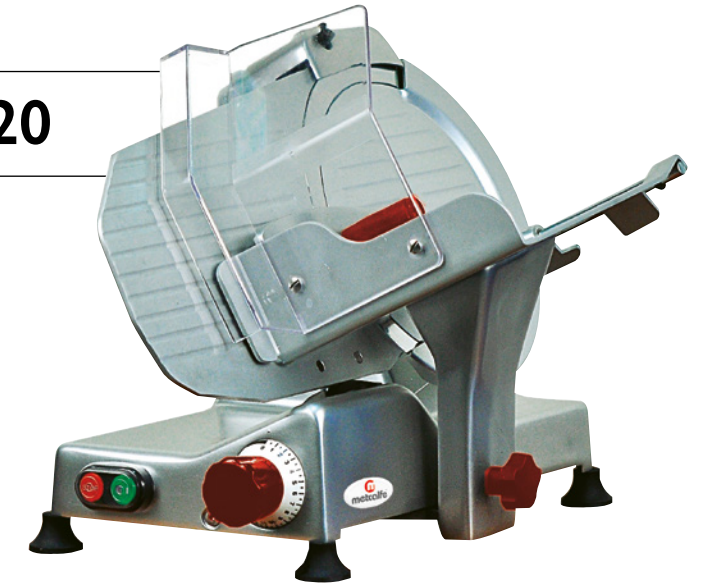

Optional custom paint

### NSL250



Optional plastic cover See p.12 for more options

MODEL	PRODUCT CODE	BLADE SIZE (mm)	CUTTING CAPACITY (mm)	MAX SLICE THICKNESS (mm)	DIMENSIONS D x W x H (mm)	NET WEIGHT (kgs)	MOTOR (watts)
NSL220	5S530N	220	<ul style="list-style-type: none"> <li>● 150</li> <li>■ 195 x 135</li> </ul>	13	400 x 525 x 410	13	130
NSL250	5S531N	250	<ul style="list-style-type: none"> <li>● 175</li> <li>■ 205 x 150</li> </ul>	13	400 x 525 x 410	17	130

## MEDIUM DUTY SLICERS

- High quality, gravity feed slicer
- Designed for light to medium duty usage. Ideally suited to smaller shops, delis, cafes, restaurants and small school kitchens
- Hollow ground chromed carbon steel blade
- Powerful twin poly 'V' belt driven transmission gives a smooth cutting action and silent running
- Easy set thickness control allows for precision slicing
- Built-in sharpening unit
- Carriage slides on ball bearings for smooth carriage glide
- Anodised aluminium body is hygienic and durable
- Transparent slicing guard to ensure ultimate user safety whilst slicing
- Entirely detachable for easy cleaning
- CE approved

### NS220 & NS250



### NS300



Optional aluminium knobs  
See p.12 for more options

MODEL	PRODUCT CODE	BLADE SIZE (mm)	CUTTING CAPACITY (mm)	MAX SLICE THICKNESS (mm)	DIMENSIONS D x W x H (mm)	NET WEIGHT (kgs)	MOTOR (watts)
NS220	5S503N	220	● 150 ■ 195 x 135	13	445 x 610 x 390	14.5	130
NS250	5S252N	250	● 175 ■ 205 x 150	13	445 x 610 x 440	20	130
NS300	5S302N	300	● 205 ■ 185 x 230	12	475 x 630 x 490	20	180

## HEAVY DUTY SLICERS

- Designed for handling larger volumes than the medium duty range. Recommended for delis, restaurants, supermarkets and canteens
- Hollow ground chromed carbon steel blade
- Powerful twin poly 'V' belt driven transmission gives a smooth cutting action and silent running
- Easy belt adjustment
- Easy set thickness control allows for precision slicing
- Carriage slides on ball bearings for smooth carriage glide
- Made from high polished, anodised food grade aluminium for durability and hygiene
- Large base to ensure slicer has a large capacity to cope with large products
- Ergonomic design with smooth rounded edges to allow for fast and easy cleaning and improved levels of hygiene
- Fully interlocked and safe guarded for full compliance of CE legislation. This ensures all-round blade protection for ultimate user safety during cleaning
- Built-in, self-aligning sharpening and de-burring unit
- Table/carriage, blade cover, blade and sharpening unit are detachable for easy, safe cleaning
- Transparent slicing guard to ensure ultimate user safety whilst slicing

### NS250HD

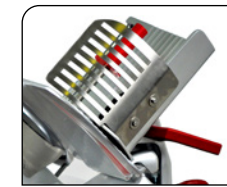

Optional stainless steel guard



### NS300HD & NS350HD



MODEL	PRODUCT CODE	BLADE SIZE (mm)	CUTTING CAPACITY (mm)	MAX SLICE THICKNESS (mm)	DIMENSIONS D x W x H (mm)	NET WEIGHT (kgs)	MOTOR (watts)
NS250HD	5S251N	250	● 175 ■ 175 x 220	12	475 x 630 x 490	19	180
NS300HD	5S301N	300	● 205 ■ 175 x 270	14	560 x 680 x 550	29	242
NS350HD	5S510N	350	● 240 ■ 200 x 270	14	560 x 700 x 600	36	370

## EXTRA HEAVY DUTY SLICERS

- Ideal machines for high volume work required in large restaurants, supermarkets, delis, butchers and central production kitchens
- Gear driven slicer designed to effortlessly handle heavy loads like bacon and large pieces of meat that might cause slipping and/or blade stoppage on a belt driven machine
- Ideal slicers for heavy cured meats including bacon, Parma ham, Serrano ham, Bresaola and salami
- Hollow ground chromed carbon steel blade
- Easy set thickness control allows for precision slicing
- Carriage slides on ball bearings for smooth carriage glide
- Made from high polished, anodised food grade aluminium for durability and hygiene
- Large base to ensure slicer has a large capacity to cope with large products
- Ergonomic design with smooth rounded edges to allow for fast and easy cleaning and improved levels of hygiene
- Fully interlocked and safe guarded for full compliance of CE legislation. This ensures all-round blade protection for ultimate user safety during cleaning
- Built-in, self-aligning sharpening and de-burring unit
- Table/carriage, blade cover, blade and sharpening unit are detachable for easy, safe cleaning
- Transparent slicing guard to ensure ultimate user safety whilst slicing

### NS300XHD & NS350XHD

**2 YEAR WARRANTY**

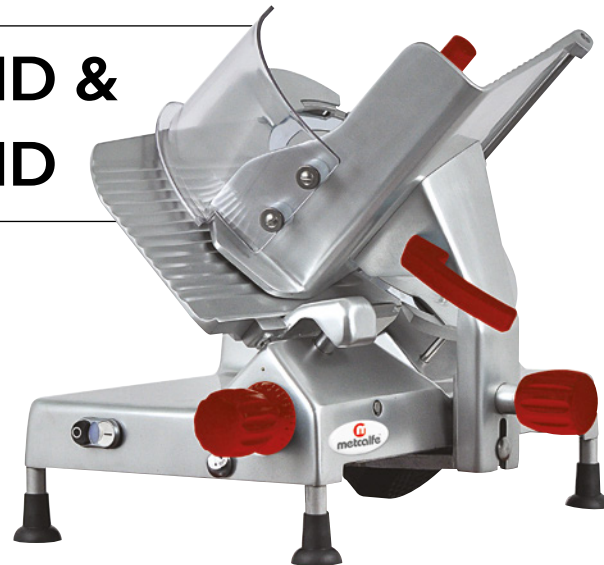

### NS370XHD

**2 YEAR WARRANTY**

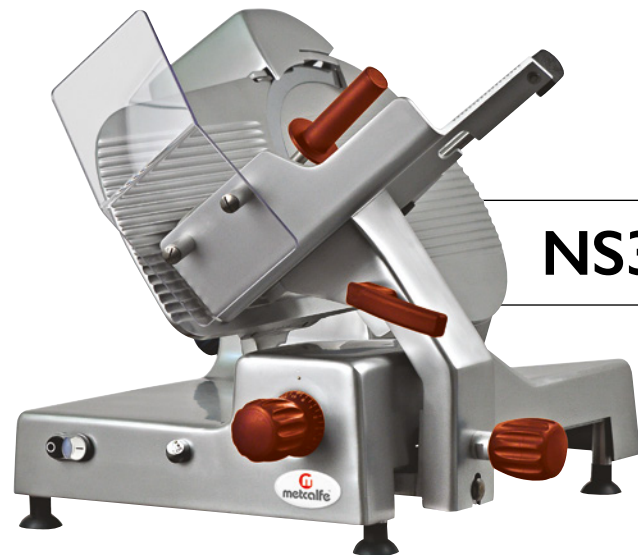

Stainless steel knife removing tool included with this model



MODEL	PRODUCT CODE	BLADE SIZE (mm)	CUTTING CAPACITY (mm)	MAX SLICE THICKNESS (mm)	DIMENSIONS D x W x H (mm)	NET WEIGHT (kgs)	MOTOR (watts)
NS300XHD	5S511N	300	● 205 ■ 175 x 270	14	560 x 680 x 610	34	300
NS350XHD	5S512N	350	● 240 ■ 200 x 270	14	560 x 700 x 640	41	300
NS370XHD	5S513N	370	● 270 ■ 220 x 300	22	695 x 825 x 690	44	370

## AUTOMATIC SLICERS

- Automatic slicer designed to cut large quantities of food. Suited to large restaurants, supermarkets, delis, butchers and central production kitchens/canteens, where high volume slicing of a variety of meat types is required and precise control of the automatic slicing feature is necessary
- Two independent motors (one for blade and one for carriage movement)
- Can be used as a fully automatic slicer or switched to manual
- Simple, intuitive touch control panels allow for the selection of multiple slicing options
- Optional slice counter available
- Hollow ground chromed carbon steel blade
- Easy set thickness control allows for precision slicing
- Carriage slides on ball bearings for smooth carriage glide
- 3 carriage movement lengths can be selected
- 3 carriage speed settings available to suit the delicacy of food being sliced
- Made from high polished, anodised food grade aluminium for durability and hygiene
- Large base to ensure slicer has a large capacity to cope with large products
- Ergonomic design with smooth rounded edges to allow for fast and easy cleaning and improved levels of hygiene
- Fully interlocked and safe guarded for full compliance of CE legislation. This ensures all-round blade protection for ultimate user safety during cleaning
- Built-in, self-aligning sharpening and de-burring unit
- Table/carriage, blade cover, blade and sharpening unit are detachable for easy, safe cleaning
- Transparent slicing guard to ensure ultimate user safety whilst slicing

### NS300A

- Heavy duty, belt driven machine

**2 YEAR WARRANTY**

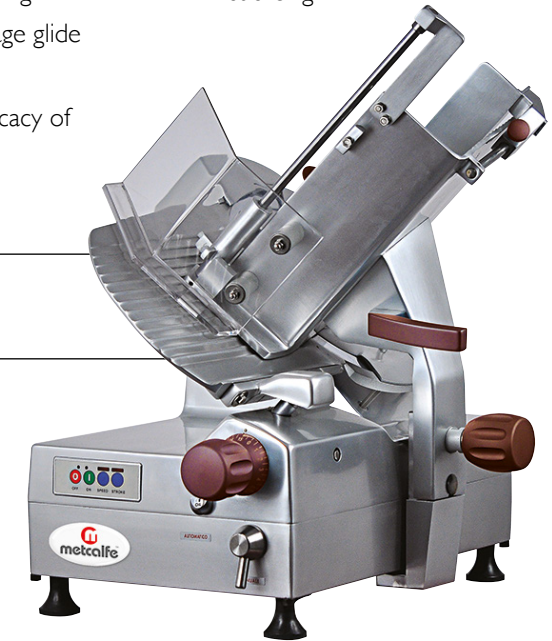

Optional Slice Counter

### NS350A & NS350AG

- NS350A is a heavy duty, belt driven machine
- NS350AG is an extra heavy duty, gear driven machine designed to effortlessly handle heavy loads like bacon and large pieces of meat that might cause slipping and/or blade stoppage on a belt driven machine
- 3 blade speed settings available for accurate slicing and to suit the delicacy of food being sliced



Optional Slice Counter



MODEL	PRODUCT CODE	BLADE SIZE (mm)	CUTTING CAPACITY (mm)	MAX SLICE THICKNESS (mm)	DIMENSIONS D x W x H (mm)	NET WEIGHT (kgs)	MOTOR (watts)
NS300A	5S514N	300	● 215 ■ 220 x 185	14	665 x 980 x 850	46	390
NS350A	5S515N	350	● 260 ■ 210 x 275	20	890 x 1030 x 850	50	570
NS350AG	5S516N	350	● 260 ■ 210 x 275	20	890 x 1030 x 850	50	570

## MEDIUM DUTY VERTICAL SLICERS

- High quality, vertical slicer
- Designed for light to medium duty usage. Ideally suited to smaller shops, delis, cafes, restaurants and small school kitchens
- Large product support surface and high side walls are ideal for slicing fresh meat and ham
- Ideal for precision slicing and delicate meats
- Hollow ground chromed carbon steel blade
- Powerful twin poly 'V' belt driven transmission gives a smooth cutting action and silent running
- Easy set thickness control allows for precision slicing
- Built-in sharpening unit
- Carriage slides on ball bearings for smooth carriage glide
- Anodised aluminium body is hygienic and durable
- Entirely detachable for easy cleaning
- CE approved

### NSV250 & NSV300

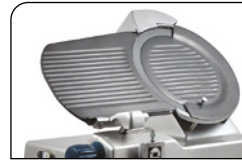

Optional Teflon coated parts

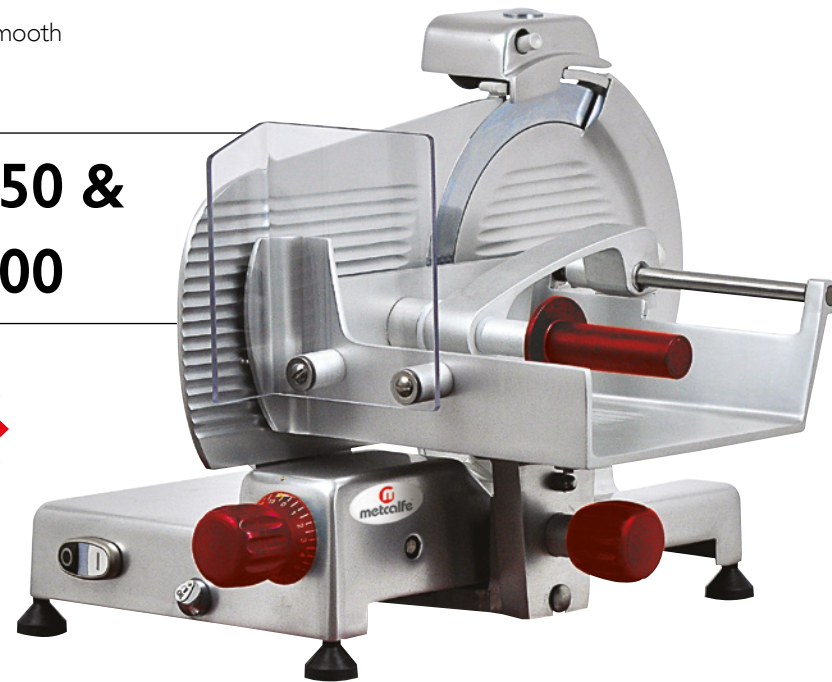

### NSV350



MODEL	PRODUCT CODE	BLADE SIZE (mm)	CUTTING CAPACITY (mm)	MAX SLICE THICKNESS (mm)	DIMENSIONS D x W x H (mm)	NET WEIGHT (kgs)	MOTOR (watts)
NSV250	5S517N	250	• 185 ■ 185 x 230	13	640 x 710 x 490	21	180
NSV300	5S518N	300	• 205 ■ 205 x 230	13	640 x 710 x 490	23	180
NSV350	5S519N	350	• 265 ■ 330 x 265	16	790 x 890 x 640	47	370

## HEAVY DUTY VERTICAL SLICERS

- Designed for handling larger volumes than the medium duty range. Recommended for delis, restaurants, supermarkets and canteens
- Large double sliding tables with lockable, clamp grips to secure product to the slicing table to aid precision slicing
- Ideal slicers for heavy cured meats including bacon, Parma ham, Serrano ham, Bresaola and salami
- Hollow ground chromed carbon steel blade
- Powerful twin poly 'V' belt driven transmission gives a smooth cutting action and silent running
- Easy belt adjustment
- Easy set thickness control allows for precision slicing
- Carriage slides on ball bearings for smooth carriage glide
- Made from high polished, anodised food grade aluminium for durability and hygiene
- Large base to ensure slicer has a large capacity to cope with large products
- Ergonomic design with smooth rounded edges to allow for fast and easy cleaning and improved levels of hygiene
- Fully interlocked and safe guarded for full compliance of CE legislation. This ensures all-round blade protection for ultimate user safety during cleaning
- Built-in, self-aligning sharpening and de-burring unit
- Table/carriage, blade cover, blade and sharpening unit are detachable for easy, safe cleaning

### NSV300HD



Special arm (protected)  
See p.12 for more options



### NSV350HD



MODEL	PRODUCT CODE	BLADE SIZE (mm)	CUTTING CAPACITY (mm)	MAX SLICE THICKNESS (mm)	DIMENSIONS D x W x H (mm)	NET WEIGHT (kgs)	MOTOR (watts)
NSV300HD	5S520N	300	• 215 ■ 215 x 280	12	600 x 780 x 595	32	242
NSV350HD	5S521N	350	• 265 ■ 265 x 310	16	710 x 900 x 585	47	370



# RETRO FLYWHEEL SLICERS



**RET300**

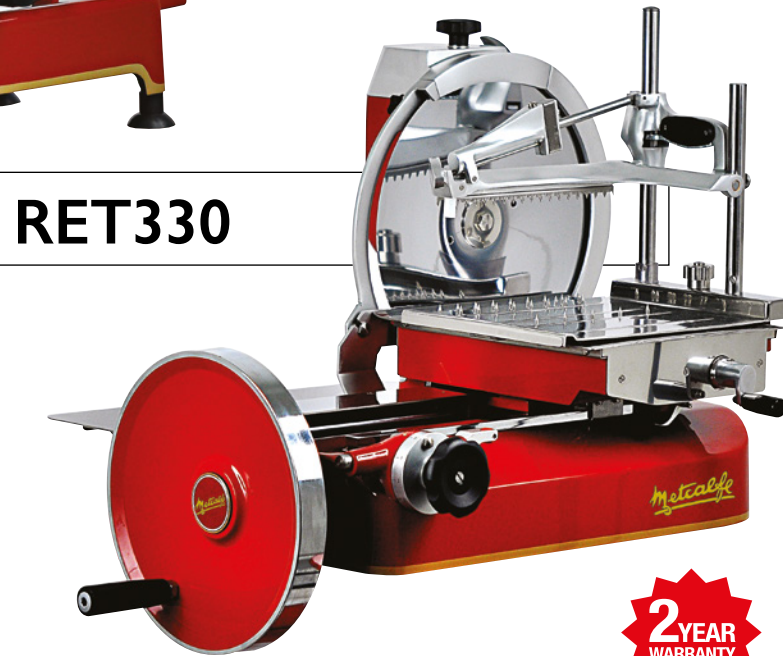

**RET330**



- Beautifully crafted, showpiece vertical slicers
- Manual and automatic options
- Available with retro style pedestal (sold separately)
- Featuring perfectly balanced chrome plated steel blades for perfect slicing results
- Able to produce very thin, accurate, sliced meats without discards and scraps
- Designed to cut all kinds of cold cuts and cured meats
- Hand crafted in aluminium and stainless steel and finished in red enamel as standard (other colours available as special order)
- Meat table and blade movement are fully co-ordinated and geared to the rotation of the flywheel
- Product being sliced moves automatically towards the blade
- Double sliding plate with lockable hand grip holds meat securely in place to ensure consistent slicing
- Large space between the blade and head for easy cleaning

MODEL	PRODUCT CODE	BLADE SIZE (mm)	CUTTING CAPACITY (mm)	MAX SLICE THICKNESS (mm)	DIMENSIONS D x W x H (mm)	NET WEIGHT (kgs)
RET300	5S506N	300	<ul style="list-style-type: none"> <li>• 215</li> <li>■ 215 x 240</li> </ul>	1.5	570 x 775 x 680	44.5
RET330	5S522N	330	<ul style="list-style-type: none"> <li>• 235</li> <li>■ 235 x 280</li> </ul>	6	675 x 815 x 610	62
RET370	5S523N	370	<ul style="list-style-type: none"> <li>• 245</li> <li>■ 245 x 315</li> </ul>	2	750 x 920 x 725	88
RET370A	5S524N	370	<ul style="list-style-type: none"> <li>• 240</li> <li>■ 240 x 310</li> </ul>	0.2-10	740 x 910 x 720	110

**RET370**



**RET370A**



- Manual flywheel or fully automatic slicer
- Simple and intuitive control panel allows the operator to select speed of blade and carriage, slice thickness and number of slices to be cut



## ACCESSORIES



Painting customisation

ACCESSORIES	PRODUCT CODE	DIMENSIONS D x W x H (mm)
Cast Iron Pedestal with Round Base	5S507N	600 x 600 x 790



Cast Iron Pedestal with Round Base

**PLEASE NOTE:** All Retro machines are special order items!

## RAPIMIX 200

- A heavy duty, commercial stick blender designed to make light work of any mixing and blending
- Ergonomic hand held blender features a powerful 250w motor capable of producing speeds of 20,000 and 15,000 rpm
- 2 speed and continuous operation selectable
- Designed to handle quantities of up to 20ltrs
- 2 metres of cable and a wall mounting cradle for ease of storage
- A fully waterproof, sealed, stainless steel shaft allows for easy cleaning and perfect food safety
- Shaft, foot and blades in stainless steel. Motor cover in solid metal casting and handle in high quality synthetics
- Capable of 8 minutes continuous use



1. Ergonomic handle design    2. 2 speed option    3. Stainless steel blade    4. Wall mounting cradle



## RAPIMIX 400 AND 500

- A heavy duty, commercial stick blender designed to make light work of any mixing and blending
- Ergonomic hand held blender features a powerful 550w motor capable of producing a top speed of 17,000 rpm
- 2 speed and continuous operation selectable
- Designed to handle quantities of up to 150 and 200 litres respectively
- 4 metres of cable and a wall mounting cradle for ease of storage
- A fully waterproof, sealed, stainless steel shaft allows for easy cleaning and perfect food safety
- Shaft, foot and blades in stainless steel. Motor cover in solid metal casting and handle in high quality synthetics
- Capable of 15 minutes continuous use



1. Ergonomic handle design    2. 2 speed option    3. Stainless steel blade    4. Wall mounting cradle



MODEL	PRODUCT CODE	PROCESSING QUANTITY (ltrs)	REVOLUTIONS (rpm)	DEPTH OF INSERTION (cms)	NET WEIGHT (kgs)	MOTOR (volt/watt/hz)
200	5SB8220	UPTO 20	15,000 or 20,000	20	1.2	230 / 250 / 50
400	5SB8209	UPTO 150	14,000 or 17,000	40	3.8	230 / 550 / 50
500	5SB8210	UPTO 200	14,000 or 17,000	50	4	230 / 550 / 50

## LIGHT DUTY SM MIXERS



### SM5 AND SM7

- Professional gear driven planetary mixer with a powerful, variable speed DC motor
- Comes complete with Beater, Whisk, Dough Hook and 5ltr / 7ltr Stainless Steel Removable Bowl
- Ideally suited to smaller shops, delis, cafes, restaurants and small school kitchens
- Fully interlocked for safety whilst in use
- Ideal for preparation of light dough, pastry, cream, mayonnaise, sauces, crème patisserie, eggs and mashed potato
- Head lifts for easy bowl and tool removal
- Constant mixing with step-less speed control
- Overload protection (NVR device)
- Plastic safety guard with ingredient chute



MODEL	PRODUCT CODE	BOWL SIZE (ltrs)	DIMENSIONS D x W x H (mm)	NET WEIGHT (kgs)	MOTOR (volt/watt/hz)	AMP (A)	SPEED (rpm)
SM5	5M237	5	403 x 236 x 437	14	230 / 350 / 50	2.1	100-938
SM7	5M238	7	403 x 236 x 437	15	230 / 350 / 50	2.1	100-938

### SM5 AND SM7 CAPACITIES

MODEL	SPONGE MIX (kgs)	LIQUID/FLOUR MIX (kgs)	EGGS	CROISSANT (kgs)	BRIOCHE (kgs)	PIZZA (kgs)	MASH (kgs)
SM5	0.9	1.0	12	1	1	0.5	1.3
SM7	1.1	1.3	14	1.3	1.3	0.7	1.5

ACCESSORIES	PRODUCT CODE
SM5 Bowl	SM5/50401040F
SM7 Bowl	SM7/50401038F
Beater	SM57/40201200F
Dough Hook	SM57/40201300F
Whisk	SM57/40202400F

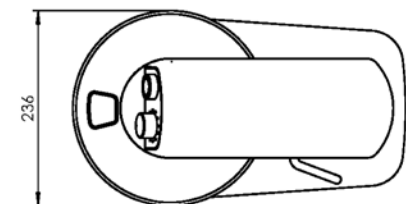
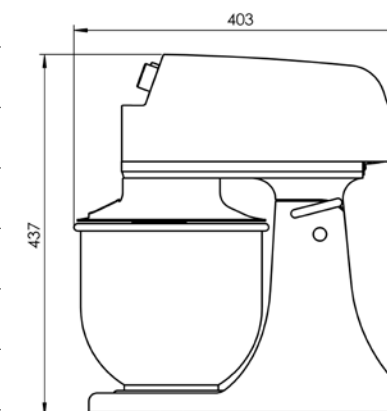



# WHY BUY METCALFE MP MIXERS?

- Heavy duty planetary drive
- Heavy duty gear box
- Powerful motor
- Heavy duty, heat treated, steel gears and shaft
- Long lasting lubricant providing abrasion resistant transmission
- Thermal overload protection (NVR device)
- Quiet operation

- Stainless steel bowl
- Beater, whisk and dough hook supplied as standard
- Stainless steel beaters and dough hooks available on request
- Bowl lift handle with microswitch (wheel on MP60)
- Fully integrated timer (except on MP20)
- Covered by Metcalfe 3-year warranty (1st year parts and labour, 2nd & 3rd years parts only) and full after sales service



## MP20-60

- Heavy duty, cast iron frame
- Attachment hub for mincer and veg prep attachment
- Reduction parts available

## MP7 & MP9

- Perspex safety guard with ingredient chute and microswitch for safe operation



MP7

MP9

MP10

MP20

MP30

MP40

MP60

## MP 7-10

- All metal and die-cast aluminium body

## MP10-60

- Emergency stop
- Stainless steel safety guard with ingredient chute and microswitch for safe operation
- Protective covers for feet to protect surfaces and provide stability
- Protective covers on bowl support

# MP MIXER COMPARISON CHART

SPECIFICATION	MP7	MP9	MP10	MP20
Bowl Capacity	7 ltr	9 ltr	10 ltr	20 ltr
Speed	5 variable speeds 193 - 495 rpm	10 variable speeds 181 - 561 rpm	3 fixed speeds 135, 243 and 480 rpm	3 fixed speeds 140, 260 and 473 rpm
Attachment Hub	No	No	No	Yes
Timer	Yes (30 min, digital)	Yes (digital)	Yes (15 min, digital)	No
Phase	Single	Single	Single	Single
Voltage	230V	230V	230V	230V
Frequency	50 Hz	50 Hz	50 Hz	50 Hz
Power	0.60 kW	0.65 kW / 0.87 HP	0.25 kW / 0.33 HP	0.375 kW / 0.5 HP
Items Included	Bowl, Beater, Whisk & Dough Hook	Bowl, Beater, Whisk & Dough Hook	Bowl, Beater, Whisk & Dough Hook	Bowl, Beater, Whisk & Dough Hook
Optional Attachments	No	No	No	Veg Prep Attachment, Mincer Attachment
Optional Accessories	No	No	No	Stand, Trolley, 10ltr Reduction Parts
Power Connection	13 Amp (3 Pin Plug)	13 Amp (3 Pin Plug)	13 Amp (3 Pin Plug)	13 Amp (3 Pin Plug)
Overall Dimensions D x W x H	460 x 340 x 490 mm	450 x 372 x 538 mm	453 x 399 x 630 mm	530 x 464 x 810 mm
Net Weight	18 kg	20 kg	62 kg	98 kg

## PRODUCT CAPACITY

Egg Whites	0.3 ltr	0.4 ltr	0.5 ltr	1 ltr
Mashed Potatoes	1.5 kg	1.8 kg	3 kg	6.8 kg
Mayonnaise (Qts. Oil)	2 ltr	2.5 ltr	3.8 ltr	9.5 ltr
Waffle/Pancake Batter	2.8 ltr	3.8 ltr	4.7 ltr	7.6 ltr
Whipped Cream	1.7 ltr	1.9 ltr	2 ltr	3.8 ltr
Fondant Icing	1 kg	1.5 kg	2.7 kg	5.4 kg
Cup/Layer Cake	2 kg	3 kg	4.8 kg	9.5 kg
Pound Cake	2 kg	3 kg	3.6 kg	9 kg
Sponge Cake	1.3 kg	1.5 kg	1.8 kg	5.4 kg
Pie Dough	1.8 kg	3 kg	4 kg	8 kg
Bread or Roll Dough (Light/Med, 60% AR)	1.8 kg	2.5 kg	5.7 kg	11.3 kg
Bread or Roll Dough (Heavy, 55% AR)	1.1 kg	1.5 kg	3.4 kg	6.8 kg
Thin Pizza Dough, Pasta, Basic Egg Noodle (40% AR) 5 min max mix time	0.8 kg	1 kg	2 kg	4 kg
Medium Pizza Dough (50% AR)	1.4 kg	1.8 kg	2.3 kg	4.5 kg
Thick Pizza Dough (60% AR)	0.9 kg	2.3 kg	4.5 kg	9 kg
Raised Donut Dough (65% AR)	0.8 kg	1 kg	2 kg	4 kg
Whole Wheat Dough (70% AR)	1 kg	1.8 kg	4 kg	9 kg

## NOTE:

The moisture content of heavy dough is a critical factor when selecting the correct mixing speed. You should never use 2nd speed when mixing heavy dough with an Absorption Ratio (AR) of 50% or less. To determine the Absorption Ratio (AR) of a product, divide the water weight by the flour weight.

Example: Calculate the Absorption Ratio of a mixture containing 50g of water and 100g of flour.  $5 \div 10 = 0.50 = 50\% = \text{AR}$

MP30		MP40		MP60	
30 ltr		40 ltr		60 ltr	
3 fixed speeds 125, 232 and 423 rpm		3 fixed speeds 95, 195 and 356 rpm		4 fixed speeds 84, 148, 248 and 436 rpm	
Yes		Yes		Yes	
Yes		Yes		Yes	
Single	Three	Single	Three	Single	Three
230 V	400 V	230 V	400 V	230 V	400 V
50 Hz	50 Hz	50 Hz	50 Hz	50 Hz	50 Hz
0.75 kW / 1 HP	0.75 kW / 1 HP	1.125 kW / 1.5 HP	1.125 kW / 1.5 HP	2.25 kW / 3 HP	2.25 kW / 3 HP
Bowl, Beater, Whisk & Dough Hook		Bowl, Beater, Whisk & Dough Hook		Bowl, Beater, Whisk, Dough Hook & Bowl Trolley	
Veg Prep Attachment, Mincer Attachment		Veg Prep Attachment, Mincer Attachment		Veg Prep Attachment, Mincer Attachment	
Bowl Trolley, 20ltr Reduction Parts		Bowl Trolley, 20ltr Reduction Parts		30ltr Reduction Parts	
Hardwired		Hardwired		Hardwired	
570 x 617 x 1105 mm		712 x 650 x 1223 mm		1039 x 782 x 1430 mm	
185 kg		205 kg		455 kg	

1.4 ltr	1.6 ltr	1.9 ltr	✓		
10.4 kg	13.6 kg	18 kg		✓	
11 ltr	12 ltr	17 ltr	✓		
11.4 ltr	15.1 ltr	22.7 ltr		✓	
5.7 ltr	8.5 ltr	11.4 ltr	✓		
8.2 kg	11.3 kg	16.3 kg		✓	
13.6 kg	20.4 kg	27 kg		✓	
11 kg	18 kg	24.9 kg		✓	
8.1 kg	16 kg	18 kg		✓	
12 kg	15.9 kg	22.7 kg		✓	
20 kg	27 kg	26 kg			✓
13.6 kg	18 kg	30 kg			✓
7 kg	13 kg	18 kg			✓
9 kg	15 kg	32 kg			✓
18 kg	21 kg	31.7 kg			✓
6.8 kg	11.3 kg	17 kg			✓
18 kg	21 kg	31.7 kg			✓

If high gluten flour is used, reduce the batch size by 10%.

Capacities listed are based on flour at room temperature and water at 20°C. If using chilled flour, water below 20°C, or ice, reduce batch size by 10%

# COUNTERTOP MP MIXERS



- Particularly suitable for bakeries, hotels, restaurants, canteens etc
- Easy to operate
- Planetary mixing action ensures perfect results
- Non-stop shifting speed
- Interlocking bowl guard and bowl lift
- Perspex safety guard with ingredient chute and automatic shut-off when guard is opened at any speed
- Overload protection (NVR device)
- Long lasting lubricant providing abrasion resistant transmission
- Transmission gears are made of heat treated, hardened steel
- All metal and die-cast aluminium body
- Quiet operation
- Supplied with Bowl, Beater, Whisk and Dough Hook
- Supplied with a 13 amp plug
- Covered by Metcalfe 3 year warranty (1st year parts and labour, 2nd and 3rd years parts only) and full after sales service

## MP7

- Heavy duty 7ltr, countertop, planetary mixer
- High torque 600w motor allows mixing of stiffer doughs and larger batches
- Automatic electronic 5-speed control and digital timer
- 5 Variable speeds from 193 rpm to 495 rpm
- 30 minute timer



## MP9

- Heavy duty 9ltr, countertop, planetary mixer
- High torque, 650 Watts motor allows mixing of stiffer doughs and larger batches
- Automatic electronic 10-speed control and digital timer
- 10 Variable speeds from 181 rpm to 561 rpm



## MP10

- Heavy duty 10ltr, countertop, belt driven, planetary mixer
- High torque motor allows mixing of stiffer doughs and larger batches
- 15 minutes timer
- Digital control panel
- 3 fixed speeds: 135, 243 and 480 rpm
- Easy speed-shifting
- Stainless steel safety guard with ingredient chute and automatic shut-off when guard is opened at any speed
- Emergency stop button
- Timing belt transmission
- Non-slip rubber feet



MODEL	PRODUCT CODE	BOWL SIZE (ltrs)	DIMENSIONS D x W x H (mm)	NET WEIGHT (kgs)	MOTOR (volt/watt/hz)	POWER (hp)	SPEED (rpm)
MP7	5MP7	7	460 x 340 x 490	18	230 / 600 / 50	n/a	193-495
MP9	5MP9	9	450 x 372 x 538	20	230 / 650 / 50	0.87	181-561
MP10	5MP10	10	453 x 399 x 630	62	230 / 250 / 50	0.33	135,243,480

ACCESSORIES	MP7 PRODUCT CODE	MP9 PRODUCT CODE	MP10 PRODUCT CODE
Bowl	MP11007-12-001	MPD10-12-001	MPBM10-12-001
Beater	MP11007-12-002	MPD10-12-002	MPBM10-12-002
Dough Hook	MP11007-12-003	MPD10-12-003	MPBM10-12-003A
Whisk	MP11007-12-004	MPD10-12-004	MPBM10-12-004

# BENCH MOUNTED OR FLOOR STANDING MIXER



## MP20

### FEATURES

- Heavy duty 20ltr; bench mounted or floor standing, gear driven, planetary mixer
- Particularly suitable for bakeries, hotels, restaurants, canteens etc
- Easy to operate
- Planetary mixing action ensures perfect results
- High torque motor allows mixing of stiffer doughs and larger batches
- 3 fixed speeds: 140, 260 and 473 rpm
- Easy speed-shifting
- Interlocking bowl guard and bowl lift
- Stainless steel safety guard with ingredient chute and automatic shut-off when guard is opened at any speed
- Industry standard #12 attachment hub
- Thermal overload protection (NVR device)
- Emergency stop button
- Long lasting lubricant providing abrasion resistant transmission
- Transmission gears are made of heat treated, hardened steel
- Heavy duty cast-iron frame
- Non-slip rubber feet
- Quiet operation
- Supplied with Bowl, Beater, Whisk and Dough Hook
- Supplied with a 13 amp plug
- Covered by Metcalfe 3 year warranty (1st year parts and labour, 2nd and 3rd years parts only) and full after sales service

### OPTIONAL EXTRAS

- Veg Prep Attachment to grate or shred all types of vegetables and fruit. 10 plate options to select from (none included)
- Meat Mincer Attachment, ideal for meat, fish and other foods. Supplied with 6mm & 8mm extrusion plates, filling tube and pusher
- 10ltr Reduction Parts
- Stand
- Trolley



MODEL	PRODUCT CODE	BOWL SIZE (ltrs)	DIMENSIONS D x W x H (mm)	NET WEIGHT (kgs)	MOTOR (volt/watt/hz)	PHASE (Ø)	POWER (hp)	SPEED (rpm)
MP20	5MP20	20	530 x 464 x 810	98	230 / 375 / 50	1	0.5	140.260.473

## ACCESSORIES

ACCESSORIES	PRODUCT CODE
Bowl	MPI1012-12-001
Beater	MPI1012-12-002
Dough Hook	MPI1012-12-003A
Whisk	MPI1012-12-004
Stand	5MP21
Mobile Trolley	5MP22
10ltr Reduction Bowl	MPI1012-12-005
10ltr Reduction Beater	MPI1012-12-006
10ltr Reduction Dough Hook	MPI1012-12-007
10ltr Reduction Whisk	MPI1012-12-008



ATTACHMENT	PRODUCT CODE
<b>Veg Prep Attachment</b> (no plates included)	MPVS12A
3mm Slicing Plate	MPVS12-013A-3MM
5mm Slicing Plate	MPVS12-013A-5MM
1.5mm Shredding Disc	MPVS12-014A-1.5MM
2mm Shredding Disc	MPVS12-014A-2MM
3mm Shredding Disc	MPVS12-014A-3MM
5mm Shredding Disc	MPVS12-014A-5MM
6mm Shredding Disc	MPVS12-014A-6MM
8mm Shredding Disc	MPVS12-014A-8MM
9mm Shredding Disc	MPVS12-014A-9MM
Grater Disc	MPVS12-014A-GRATER
<b>Meat Mincer Attachment</b> supplied with 6mm & 8mm Extrusion Plates, Filling Tube and Pusher	MPG12SH



# FLOOR STANDING MIXERS

## MP30, MP40 & MP60



### FEATURES

- Heavy duty, floor standing, gear driven, planetary mixers
- Particularly suitable for bakeries, hotels, restaurants, canteens etc
- Easy to operate
- Planetary mixing action ensures perfect results
- High torque motor allows mixing of stiffer doughs and larger batches
- Easy speed-shifting
- Timer
- Emergency stop button
- Interlocking bowl guard and bowl lift
- Dual bowl clamps to lock bowl down
- Stainless steel safety guard with ingredient chute and automatic shut-off when guard is opened at any speed
- Resettable thermal overload protection (NVR device)
- Long lasting lubricant providing abrasion resistant transmission
- Transmission gears are made of heat treated, hardened steel
- Heavy duty, cast iron frame
- Non-slip rubber feet
- Quiet operation

- Heavy duty gearbox
  - Industry standard #12 attachment hub
  - Covered by Metcalfe 3 year warranty (1st year parts and labour, 2nd and 3rd years parts only) and full after sales service
- OPTIONAL EXTRAS
- Veg Prep Attachment to grate or shred all types of vegetables and fruit. 10 plate options to select from (none supplied)
  - Meat Mincer Attachment, ideal for meat, fish and other foods. Supplied with 6mm & 8mm plates, filling tube and pusher
  - Reduction Parts
  - Bowl Trolley (included as standard with MP60)



MODEL	PRODUCT CODE	BOWL SIZE (ltrs)	DIMENSIONS D x W x H (mm)	NET WEIGHT (kgs)	MOTOR (volt/kW/hz)	POWER (hp)	SPEED (rpm)
MP30-1ph	5MP30-1PH	30	570 x 617 x 1105	185	220-240 / .75 / 50	1	125.232.423
MP30-3ph	5MP30-3PH	30	570 x 617 x 1105	185	380-415 / .75 / 50	1	125.232.423
MP40-1ph	5MP40-1PH	40	712 x 650 x 1223	205	220-240 / 1.125 / 50	1.5	95.195.356
MP40-3ph	5MP40-3PH	40	712 x 650 x 1223	205	380-415 / 1.125 / 50	1.5	95.195.356
MP60-1ph	5MP60-1PH	60	1039 x 782 x 1430	455	220-240 / 2.25 / 50	1.5	84.148.248.436
MP60-3ph	5MP60-3PH	60	1039 x 782 x 1430	455	380-415 / 2.25 / 50	1.5	84.148.248.436

### ACCESSORIES



ACCESSORIES	MP30 PRODUCT CODE	MP40 PRODUCT CODE	MP60 PRODUCT CODE
Bowl	MP11031-12-001	MP11040-12-001	MP11091-12-008
Beater	MP11031-12-002	MP11040-12-002	MP11091-12-001
Dough Hook	MP11031-12-003	MP11040-12-003	MP11091-12-003
Whisk	MP11031-12-004	MP11040-12-004	MP11091-12-002
Bowl Trolley	MP11031-12-005	MP11040-12-011	MP11091-12-011
Reduction Bowl	MP11031-12-001M (20ltr)	MP11040-12-001M (20ltr)	MP11091-12-007 (30ltr)
Reduction Beater	MP11031-12-002M (20ltr)	MP11040-12-002M (20ltr)	MP11091-12-004 (30ltr)
Reduction Dough Hook	MP11031-12-003M (20ltr)	MP11040-12-003M (20ltr)	MP11091-12-006 (30ltr)
Reduction Whisk	MP11031-12-004M (20ltr)	MP11040-12-004M (20ltr)	MP11091-12-005 (30ltr)

ATTACHMENT	PRODUCT CODE
<b>Veg Prep Attachment</b> (no plates included)	MPVS12A
3mm Slicing Plate	MPVS12-013A-3MM
5mm Slicing Plate	MPVS12-013A-5MM
1.5mm Shredding Disc	MPVS12-014A-1.5MM
2mm Shredding Disc	MPVS12-014A-2MM
3mm Shredding Disc	MPVS12-014A-3MM
5mm Shredding Disc	MPVS12-014A-5MM
6mm Shredding Disc	MPVS12-014A-6MM
8mm Shredding Disc	MPVS12-014A-8MM
9mm Shredding Disc	MPVS12-014A-9MM
Grater Disc	MPVS12-014A-GRATER
<b>Meat Mincer Attachment</b> supplied with 6mm & 8mm Extrusion Plates, Filling Tube and Pusher	MPG12SH



# PASTA MACHINES



- Fresh pasta machine with mixer and screw extruder for making various types of pasta. Suitable for small facilities and for domestic use, it features an output of up to 2.5 kg/h and a tank with a capacity of 1.3 kg
- All components that come into contact with food are made of stainless steel or food grade bronze
- All moving parts are installed on ball bearings with long-life seals
- Single-motor-driven, belt drive with maintenance-free reduction gear and chain for the mixer
- Machine equipped with height-adjustable feet and plastic caps
- Flame retardant power cord with plug
- Operating components can rotate in both directions
- The operating parts are easy to disassemble to allow access for cleaning the machine
- Allows you to make various pasta shapes by simply changing the die
- No dies supplied with machine
- Accessories available: Cutting assembly for short pasta, Cart and Dies (see page 30 for full list)

## TR50



- Fresh pasta machine for the production of various pasta shapes and sizes, with mixer and screw extruder. Wide range of fittings and dies available
- Production per hour 4 kg
- All components that come into contact with food are made of stainless steel or food grade bronze
- All moving parts are installed on ball bearings with long-life seals or supports with grease gun
- Single-motor-driven, belt drive with maintenance-free reduction gear. Mixer driven by sprocket
- Equipped with height-adjustable feet and plastic caps
- Flame retardant power cord and plug according to the required power supply
- Operating components can rotate in both directions
- The operating parts are easy to disassemble to allow access for cleaning the machine
- Allows you to make various pasta shapes by simply changing the die
- No dies supplied with machine
- Accessories available: Cutting assembly for short pasta, Cart and Dies (see page 30 for full list)

## TR70



- Fresh pasta machine for the production of various pasta shapes and sizes, with mixer and screw extruder. Wide range of fittings and dies available
- It has an output of 8 kg per hour
- All components that come into contact with food are made of stainless steel or food grade bronze
- Electronic cutter and fan to ensure the product e.g. spaghetti, doesn't stick
- Featuring a sleeve cooling unit to keep the head's temperature constant, preventing the dough falling apart
- No dies supplied with machine
- Accessories available: Trolley, Cart and Dies (see page 30 for full list)

## TR75

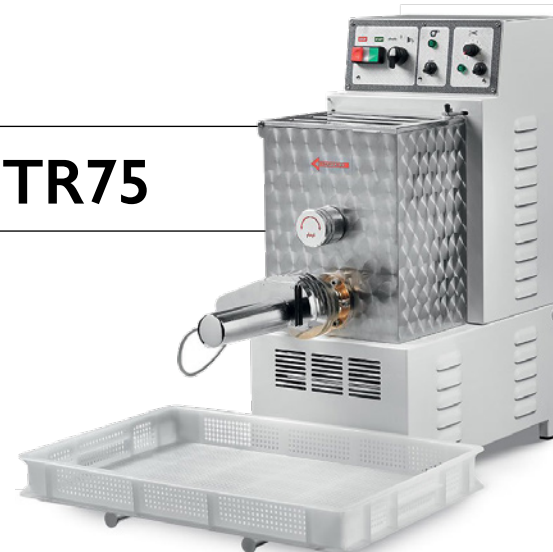

## PASTA MACHINE COMPARISON CHART

MODEL	TR50	TR70	TR75
PRODUCT CODE	5TR50	5TR70	5TR75
Dough capacity (kgs)	1.3	1.7	5
Max hourly production (kg/h)	2.5	4	8
Dimensions W x D x H (mm)	270 x 380 x 325	250 x 440 x 425	320 x 750 x 725
Motor power (kw)	0.38	0.38	0.75
Power (V/hz)	230 / 50	230 / 50	230 / 50 1ph 380 / 50 3ph
Single or three phase power	Single phase	Single phase	Single or three phase*
Net weight (kgs)	21	28	68
Width of pasta sheet (mm)	130	160	180
Electronic cutter & fan	-	-	Yes
Sleeve & cooling unit	No	No	Yes
Dies available	Standard Teflon Adjustable sheet	Standard Teflon Adjustable sheet	Standard Teflon Adjustable sheet Fixed sheet Penne
Liquid measuring jug included	Yes	Yes	Yes
Optional accessories	Plastic pasta tray Stainless steel cart with 5 trays Short pasta cutter assembly	Plastic pasta tray Stainless steel cart with 5 trays Short pasta cutter assembly	Plastic pasta tray Stainless steel cart with 5 trays Trolley (H 660 mm)

\*Stocked in 1ph. 3ph available on request

## ACCESSORIES

ACCESSORIES	PRODUCT CODE
Cutting Assembly for TR50	LPC01
Cutting Assembly for TR70	LPC02
Stainless Steel Cart with 5 Trays	LPC03
Trolley for TR75	LPT01
Plastic Pasta Tray (40 cm x 60 cm)	LPT02

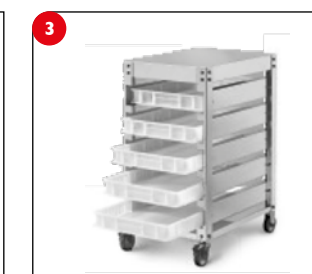

1. Cutter Motor Assembly
2. Trolley for TR75
3. Stainless Steel Cart with 5 Trays

## LA PASTAIA PASTA DIES

PASTA DIES	TR50	TR70	TR75	PASTA SHAPE
N. 3 Spaghetti 0.8 mm	✓✓	✓✓	✓✓	
N. 5 Spaghetti 1.1 mm	✓✓	✓✓	✓✓	
N. 8 Spaghetti 1.7 mm	✓✓	✓✓	✓✓	
N. 12 Spaghetti 2.5 mm	✓✓	✓✓	✓✓	
Spaghetti Quadri 2.5 x 2.5 mm	✓✓	✓✓	✓✓	
N. 18 Linguine 3.0 x 1.6 mm	✓✓	✓✓	✓✓	
N. 21 Tagliolini 1.8 mm	✓✓	✓✓	✓✓	
N. 23 Tagliolini 2.6 mm	✓✓	✓✓	✓✓	
N. 26 Fettuccine 6 mm	✓✓	✓✓	✓✓	
N. 28 Fettuccine 10 mm	✓✓	✓✓	✓✓	
N. 30 Pappardelle 14 mm	✓✓	✓✓	✓✓	
N. 31 Pappardelle 17 mm	✓	✓✓	✓✓	
N. 47 Reginette 9 mm	✓	✓✓	✓✓	
N. 59 Bucatini 3 mm	✓✓	✓✓	✓✓	
N. 90 Maccheroncini 4.8 mm	✓✓	✓✓	✓✓	
N. 99 Maccheroni 8 mm	✓✓	✓✓	✓✓	
N. 105 Rigatoni 11 mm	✓✓	✓✓	✓✓	
N. 108 Rigatoni 15 mm	✓	✓	✓	
N. 122 Penne Rigate 8.8 mm			✓✓	
N. 127 Tortiglione 8.8 mm	✓✓	✓✓	✓✓	
N. 131 Fusilli A 2 Principi	✓✓	✓✓	✓✓	
N. 133 Fusilli A 3 Principi 10 mm	✓✓	✓✓	✓✓	
N. 163 Pipe Rigate 16 mm	✓	✓	✓	
N. 190 Conchiglie Rigate 28 mm	24 mm ✓	✓	✓	
N. 240 Fusilli A 3 Principi	✓✓	✓✓	✓✓	
N. 251 Gigi	✓✓	✓✓	✓✓	
N. 382 Gnocchetto Sardo 19 mm	12 mm ✓	✓	✓	
N. 386 Casarecce	✓✓	✓✓	✓✓	
Amori		✓	✓	
Gargati *	✓	✓	✓	
Pacchero *	✓ ●	✓ ●	✓ ●	
Sheet die with fix thickness		✓	✓	
Sheet die with adjustable thickness (allen key included)	✓	✓	✓	

✓ Brass ✓ Teflon ● brass inserts, 1 exit on the die cut by hand only \*special shape, price +20%



## WHY BUY METCALFE PEELERS?

### Q BENCH PEELER FEATURES

- On/off switches on back cover
- V belt drive with powerful 0.33hp motors
- Patented peeling chamber design: Abrasive integrally cast into wall of chamber which dispenses with the need to replace abrasive coating for the life of the peeler. Produces smoother peeled produce
- Water inlet and waste outlet on left or right side of machine to allow for easy setup/installation
- Rotor plate coated on both sides, doubling its life. Fine abrasive for new potatoes and root vegetables and coarse abrasive for regular potatoes



- Unique stainless steel bearings and drive shaft sealed for maintenance-free use
- Available in hammer grey or natural aluminium finish
- Sink/counter top, pedestal or trolley mounted
- Heavy duty cast aluminium

### Q PEDESTAL PEELER FEATURES

- Patented peeling chamber design: Abrasive integrally cast into wall of chamber which dispenses with the need to replace abrasive coating for the life of the peeler. Produces smoother peeled produce
- Optional waste disposal adaptor to effectively flush away peeling sludge
- Powerful direct gear drive motor, 1/2hp, (single or 3 phase available)
- Choice of high or low pedestal
- Pedestal can be bolted to the floor for secure operation
- Unique 'flexible coupling' fitted to protect gearbox and motor in the event of a rotor plate jam and/or overload
- Optional guarded discharge chute protects operator
- Heavy duty aluminium casting
- Peeler supplied with wall mounted start/stop box



# BENCH MOUNTED PEELERS

## EPI0 & NAI0



## EPI5 & NAI5

- Medium duty, bench mounted potato peelers constructed from food grade, non-corrosive aluminium alloy castings in two capacities: 4.5 kg (10 lb) and 6.8 kg (15 lb)
- Spindle housing and chute cast integrally, eliminating joints and possible leakage
- Available in grey hammer paint finish or in a natural aluminium
- Pedestal is 90cm high, making the discharge chute 94cm high
- Sink-top/counter-top, pedestal or trolley mounted
- Complies with all relevant safety standards and designed for ease of maintenance and cleaning
- No lubrication is required. All bearings are grease packed and permanently sealed
- V- belt driven for noiseless transmission, with provision for belt tensioning if required
- Rotor plate coated on both sides, doubling its life. Fine grained abrasive for new potatoes on one side and coarse grained for regular potatoes on the other
- Inside wall of peeling chamber has patented cast-in abrasive serrations which dispenses with the need for abrasive coating. Consequently there is less potato loss during both peeling and boiling and the efficiency of the serrations will last the life of the machine
- Spun lid removable without tools so that the rotor plate can be lifted out. Turn on water and the whole machine is flushed clean. Cleaning should be carried out on a daily basis
- Water inlet. Hose union with nozzle and provision for fitting on either side
- Water outlet. Tapped 1 1/2" BSP ready for waste pipe to be connected. Provision for fitting on either side

MODEL	PRODUCT CODE	FINISH	CAPACITY (kgs)	DIMENSIONS D x W x H (mm)	OUTPUT (kgs per hour)	NET WEIGHT (kgs)	MOTOR (kW / hp)
EPI0	5PI01	Hammer grey painted	4.5	576 x 339 x 365	27	27	0.25 / 0.33
NAI0	5PI03	Natural aluminium	4.5	576 x 339 x 365	27	27	0.25 / 0.33
EPI5	5PI51	Hammer grey painted	6.8	576 x 339 x 416	41	30	0.25 / 0.33
NAI5	5PI53	Natural aluminium	6.8	576 x 339 x 416	41	30	0.25 / 0.33

# ACCESSORIES

PHOTO NO.	ACCESSORIES	PRODUCT CODE
1	<b>Guarded Discharge Chute Painted Finish</b>	9T19
	<b>Guarded Discharge Chute Stainless Steel Finish</b>	9T24
	Protects the operator by allowing the door to be opened which stops hand access through the door aperture whilst the machine is working	
2	<b>Type 'AA' Air Gap Tundish</b>	9T25
	Fitted in place of the standard water inlet supplied with all Metcalfe peelers. The use of a tundish meets the requirements of water regulations G19.1, G19.3 & G19.4 contained in "The Water Supply Regulations 1999" and the "Water Byelaws 2000 (Scotland)"	
3	<b>Small External Interceptor with tank and basket</b>	9T22
4	<b>Small Waste Disposal Adaptor</b>	9T17
	Waste pipe can be connected direct to the drain. Gives an additional water supply to the waste outlet to flush away the sludge. Water Byelaws Scheme approved product when connected to water header tank	
5	<b>Mobile Trolley</b>	9T21
6	<b>Pedestal</b>	9T20
7	<b>Sink Skip</b>	TS06
8	<b>Length of Waste Pipe, Elbow and Coupling</b>	9T18
9	<b>3ft. Length Water Inlet Hose and Tap Connector</b>	9P64
7-9	<b>Installation Kit</b>	9T28
	3ft. Length Water Inlet Hose, Tap Connector, Length of Waste Pipe, Elbow, Coupling and Sink Skip	

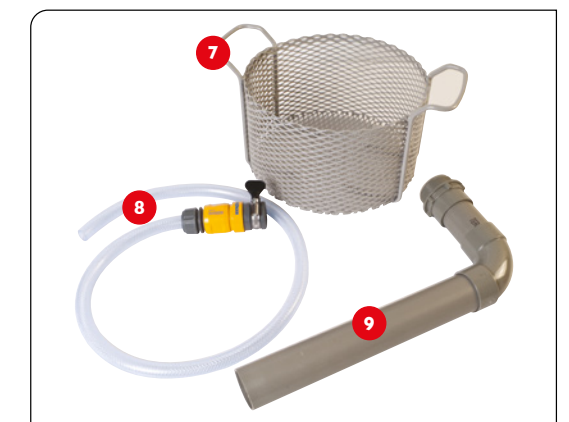
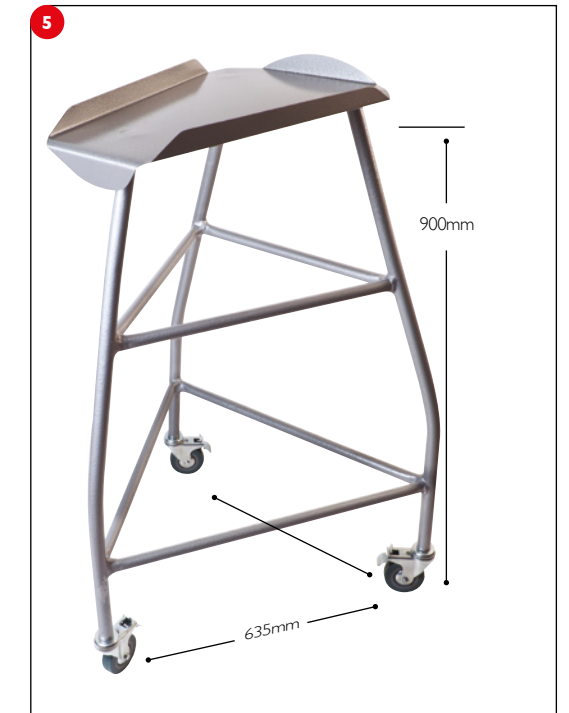
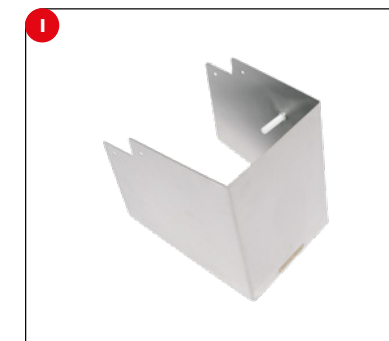



# PEDESTAL PEELERS



**GU4**

Model pictured: GU4 Low pedestal.



**GU8**

Model pictured: GU8 High pedestal. Shown with guarded discharge chute and waste disposal adaptor (optional extras).

- Heavy duty pedestal peelers with powerful direct gear drive motors. The 6.3 kg (14 lb) and the 12.6 kg (28 lb) models have 0.5hp geared units
- Low or high (sink height) pedestal models available
- Designed to enable the user to operate, clean and maintain with the minimum of effort
- Motor and gearbox units are housed inside the pedestal therefore no external projections
- Hammer grey painted finish
- The drive between the output shaft of the unit and the drive shaft of the peeler is by means of a flexible coupling which will prevent damage to the motor or gearbox if the machine is accidentally jammed or overloaded
- Top casting removable without tools so that the rotor plate can be lifted out. Turn on water and the whole machine is flushed clean. Cleaning should be carried out on a daily basis
- Rotor plate is bonded with abrasive grit.
- Inside wall of peeling chamber has patented cast-in abrasive serrations which dispenses with the need to replace abrasive coating for the life of the peeler. Consequently there is less potato loss during both peeling and boiling and it produces smoother peeled produce
- All Metcalfe pedestal peelers are available with either single phase or three phase motors
- All single phase peelers are supplied with a wall mounted starter which incorporate the 'on' switch, emergency stop and no-volt release, overload protection features and are fitted with a 13 amp plug
- All three phase peelers are supplied with cord only
- Machines fitted with a water inlet and hose connection incorporating an air break. Stop tap can be fitted if required. Provision for fitting water inlet on either side of machine
- Waste outlet screwed 2" BSP female

MODEL	PRODUCT CODE	CAPACITY (kgs)	DIMENSIONS D x W x H (mm)	OUTPUT (kgs per hour)	NET WEIGHT (kgs)	MOTOR (kW / hp)
GU4 – Low pedestal 1ph	5P145	6.3	491 x 476 x 975	38	60	0.37 / 0.5
GU4 – Low pedestal 3ph	5P146	6.3	491 x 476 x 975	38	60	0.37 / 0.5
GU4 – High pedestal 1ph	5P147	6.3	491 x 476 x 1204	38	64	0.37 / 0.5
GU4 – High pedestal 3ph	5P148	6.3	491 x 476 x 1204	38	64	0.37 / 0.5
GU8 – Low pedestal 1ph	5P285	12.6	573 x 533 x 1018	76	67	0.37 / 0.5
GU8 – Low pedestal 3ph	5P286	12.6	573 x 533 x 1018	76	67	0.37 / 0.5
GU8 – High pedestal 1ph	5P287	12.6	573 x 533 x 1247	76	71	0.37 / 0.5
GU8 – High pedestal 3ph	5P288	12.6	573 x 533 x 1247	76	71	0.37 / 0.5

# ACCESSORIES

PHOTO NO.	ACCESSORIES	PRODUCT CODE
1	<b>Guarded Discharge Chute for GU4</b> <b>Guarded Discharge Chute for GU8</b> protects the operator by allowing the door to the chamber to be opened which stops hand access through the door aperture whilst the machine is working	9P59 9P60
2	<b>Type 'AA' Air Gap Tundish</b> Fitted in place of the standard water inlet supplied with all Metcalfe peelers. The use of a tundish meets the requirements of water regulations G19.1, G19.3 & G19.4 contained in "The Water Supply Regulations 1999" and the "Water Byelaws 2000 (Scotland)"	9T25
3	<b>3ft. Length Water Inlet Hose and Tap Connector</b>	9P64
4	<b>Waste Disposal Adaptor with tank and basket</b> Waste pipe can be connected direct to the drain. Gives an additional water supply to the waste outlet to flush away the sludge. Water Byelaws Scheme approved product when connected to water header tank	9P57
5	<b>Large External Interceptor</b>	9P27

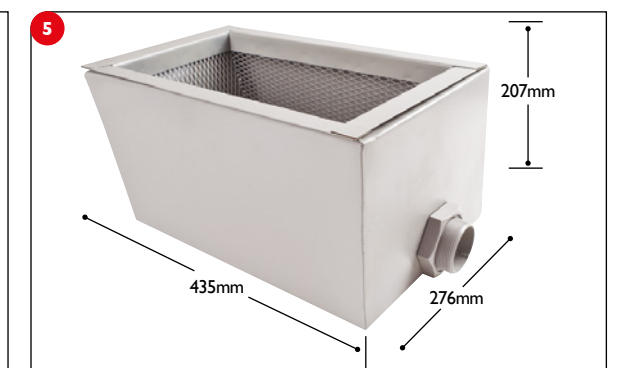
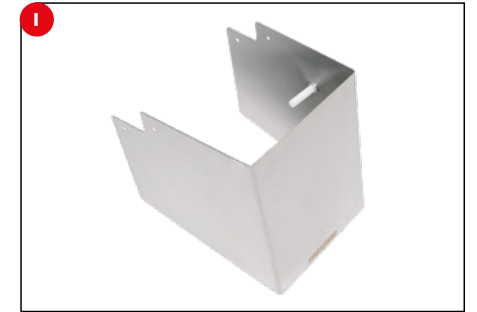

# CHIPPERS

Metcalfe's HPC is a manual, detachable block chipper, for use with peeled potatoes.

- Removable bottom knife frame as well as removable upper block for easy and thorough cleaning
- Cutting sizes available: 8mm, 10mm, 12.5mm, 14mm or 8 piece potato wedger
- Heavy duty chromium plated spring
- Double roller action for easy operation
- Chromium plated handle for lasting wear
- White acrylic enamel finish
- Easy release knob for upper chipping head
- Bench or floor mounting stands available

MODEL	PRODUCT CODE	OVERALL DIMENSIONS D x W x H (mm)	NET WEIGHT (kgs)
Detachable Block Chipper (Chassis Only)	5HC10	320 x 140 x 610	15.5

BLOCK KNIVES & FRAME	PRODUCT CODE
Block, Knives and Frame Set - 8mm (5/16")	9HC21
Block, Knives and Frame Set - 10mm (3/8")	9HC22
Block, Knives and Frame Set - 12.5mm (1/2")	9HC23
Block, Knives and Frame Set - 14mm (5/8")	9HC24
Block, Knives and Frame Set - 8 piece wedger	9HC17

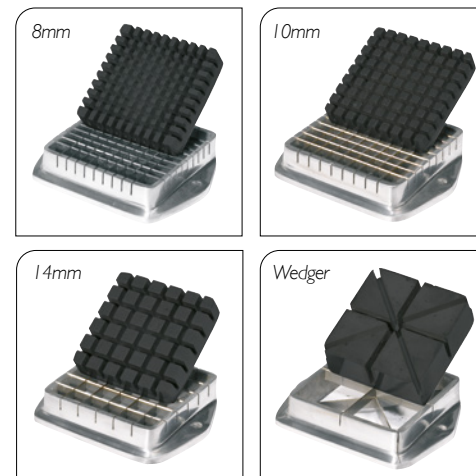

## ACCESSORIES

- Illustrated are our bench mounting stand and floor mounting stand
- The bench mounting stand eliminates the need to drill holes in the work surface to secure the chipper
- The tubular steel floor mounting stand is designed to give the machine the correct operating height and has adequate space for a large receptacle to receive the chips

ACCESSORIES	PRODUCT CODE	OVERALL DIMENSIONS D x W x H (mm)	NET WEIGHT (kgs)
Bench Mounting Stand	5HC07	440 x 370 x 250	3
Floor Mounting Stand	5HC04	490 x 560 x 820	6



# EC20

The Metcalfe EC20 Heavy Duty Electric Chipper is a fully automatic, high volume chip cutter with the highest capacity available on the market. The large hopper has a capacity of 20kg with a production capacity of 50kg of chips per minute, with minimum waste. For use with peeled potatoes.

The EC20 features fully interchangeable knife assemblies available in variable chipping sizes from 10mm, 12mm, 14mm and 16mm. (Custom sizes are available on request).

Manufactured from high grade 304 stainless steel the EC20 is food safe, long lasting and durable for use in the harshest of commercial foodservice environments. The hopper, knife block and rotary feed are all removable for easy cleaning without the need for complicated removal tools.

- Production capacity of over 50kgs of chips per minute, 192 rpm
- Total capacity of 20kgs, including hopper
- Interchangeable knife assembly offers a choice of four chip sizes: 10mm, 12mm, 14mm & 16mm (custom sizes are available on request)
- The unit is not supplied with a knife assembly, please specify your preferred chip size(s) when ordering
- For use with peeled potatoes
- Vee belt drive pulley for reliability and strength
- Manufactured from high grade 304 food safe stainless steel extending product life
- Heavy duty machined components for longer product life
- Thicker gauge material for a solid, more robust product
- Hopper, knife assembly and rotary feed are all removable for easy cleaning without the need for complicated removal tools
- All removable parts are dishwasher safe
- Stainless steel hopper with built-in ingredient baffles allows free movement of potatoes
- Zero volt reset preventing unplanned start-ups
- Safety interlocked hopper and knife block preventing unsafe use
- Emergency stop button, IP65 rated, preventing ingress of water
- Hand screw locking mechanism ensuring a full stop occurs before access to rotating parts
- Motor thermal protection preventing overheating and damage
- Counter-top mounting or optional floor stand available
- Non-slip rubber feet preventing unwanted chipper movement
- CE & UKCA approved



MODEL	PRODUCT CODE	DIMENSIONS D x W x H (mm)	OUTPUT (kgs per minute)	NET WEIGHT (kgs)	POWER (volt/hz)	MOTOR (hp/kw)
EC20	5EC22	665 x 390 x 691	50	30	230 / 50	0.25 / 0.18, 1ph

KNIFE ASSEMBLIES	PRODUCT CODE
10mm Knife Assembly	9ECM01
12mm Knife Assembly	9ECM02
14mm Knife Assembly	9ECM03
16mm Knife Assembly	9ECM04

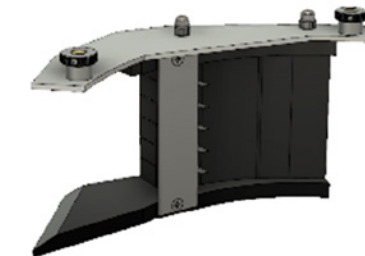

ACCESSORIES	PRODUCT CODE	DIMENSIONS D x W x H (mm)
Floor Stand	5EC24	510 x 460 x 590
Floor Trolley	5EC25	510 x 460 x 590



# GRATERS

## GMR - RETRO CHEESE GRATER

- Retro style cheese grater offering excellent performance with an output of 30kgs of cheese and 50kgs of bread per hour
- The grater has a special steel roll and is protected with a stainless steel grid to avoid contact with moving parts
- An interlock is assembled on the cheese pressing handle; it is started when the cheese load safety threshold is exceeded to avoid contact with the moving cutting part
- **Only suitable for grating hard cheese (e.g. pecorino and parmesan), bread, nuts and biscuits**



MODEL	PRODUCT CODE	DIMENSIONS D x W x H (mm)	GRATING CHAMBER (mm)	OUTPUT (kgs per hour)	NET WEIGHT (kgs)	MOTOR (kw/hp)
GMR	5GMR01	280 x 170 x 310	110 x 65	30	8	0.38 / 0.5

## GSD - CHEESE GRATER

- Professional cheese grater offering excellent performance with an output of up to 70kg of grated cheese per hour
- The grater has a special steel roll and is protected with a stainless steel grid to avoid contact with moving parts
- An interlock is assembled on the cheese pressing handle; it is started when the cheese load safety threshold is exceeded to avoid contact with the moving cutting part
- **Only suitable for grating hard cheese (e.g. pecorino and parmesan), bread, nuts and biscuits**
- Ventilated motor with heat sensor
- On/off switch protection with waterproof rubber cover
- Plastic base protection to prevent moisture entering the motor and electrics



MODEL	PRODUCT CODE	DIMENSIONS D x W x H (mm)	GRATING CHAMBER (mm)	OUTPUT (kgs per hour)	NET WEIGHT (kgs)	MOTOR (kw/hp)
GSD	5GSD01	380 x 220 x 380	140 x 80	70	18	0.75 / 1

## TMC - MOZZARELLA CHEESE GRATER

- Professional mozzarella cheese grater ideally suited for pizza shops and restaurants
- Output of up to 50kg per hour
- 4 cutting cones available:  
No.1: 2mm for slicing  
No.2: 2.5mm for shredding or grating  
No.3: 4mm for vegetables  
No.4: 7mm for mozzarella cheese
- Unit is supplied with a 7mm cone
- Stainless steel construction
- Heavy duty motor
- Thermal overload protection included
- 24volt control panel ensures safety during operation
- ABS discharging chute equipped with safety micro switch
- ABS pestle
- Stainless steel cutting cones, hopper and tray
- Available in single or three phase



MODEL	PRODUCT CODE	DIMENSIONS D x W x H (mm)	OUTPUT (kgs per hour)	NET WEIGHT (kgs)	MOTOR (kw/hp)
TMC	5TMC102	420 x 220 x 440	50	18	0.75 / 1

ACCESSORIES	PRODUCT CODE	ACCESSORIES	PRODUCT CODE
No. 1 Cone: 2mm holes for slicing	FM2282	No. 3 Cone: 4mm holes for vegetables	FM2281
No. 2 Cone: 2.5mm holes for shredding or grating	FM2280	No. 4 Cone: 7mm holes for mozzarella cheese	FM2182

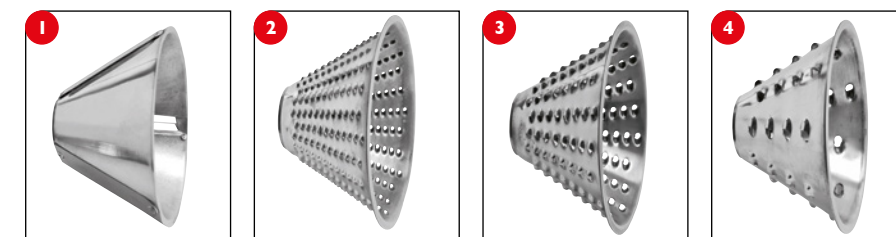

# MINCERS

## TS12R - RETRO MEAT MINCER

- Retro style meat mincer offering excellent performance with an output of 200kgs of meat per hour
- The stainless steel grinding unit can be completely separated from the machine body for accurate and effective cleaning
- 6mm mincing plate included



## TS22 - MEAT MINCER

- Small but powerful commercial meat mincer, made from die cast aluminium and stainless steel
- Capable of producing up to 300kgs of mince per hour
- Full overload protection
- Stainless steel tray and hopper
- Grinding unit can be removed completely for easy cleaning
- On/off switch protection with waterproof rubber cover
- Plastic base protection to prevent moisture entering the motor and electrics
- 6mm mincing plate included



MODEL	PRODUCT CODE	EXTRUSION MOUTH DIAMETER (mm)	OUTPUT (kgs per hour)	DIMENSIONS D x W x H (mm)	NET WEIGHT (kgs)	MOTOR (hp)
TS12R	5MMTS12R	70	200	370 x 220 x 440	19	1
TS22	5MMTS22	82	300	440 x 240 x 510	24	1.5
Ti22R	5MMSTC22	82	400	450 x 260 x 530	32	2
Ti32R	5MMSTC32	98	600	475 x 300 x 560	52	3

## Ti22R & Ti32R - MEAT MINCERS



- Structured in cast alloy covered entirely in stainless steel
- Self-ventilated motor
- Speed reducer with 4 oil-immersed gears made from hardened steel enclosed in an oil-tight gearcase
- Stainless steel feedbox and meat pick-up tray
- With the simple turning of a lever the mincing set is disengaged
- All the machine parts can easily be cleaned with a damp cloth
- 6mm mincing plate included

ACCESSORIES	TS12R PRODUCT CODE	TS22/TI22R PRODUCT CODE	TI32R PRODUCT CODE
Extrusion Plate – 3mm	FM0407/3	FM0410/3	FM0413/3
Extrusion Plate – 3.5mm	FM0405/3.5	FM0411/3.5	FM0414/3.5
Extrusion Plate – 4.5mm	FM2131/4.5	FM2219/4.5	FM0502/4.5
Extrusion Plate – 6mm	FM2131/6	FM2219/6	FM0502/6
Extrusion Plate – 8mm	FM2131/8	FM2219/8	FM0502/8
Knife	FM2130	FM2218	FM0503

## HAMBURGER PRESS

- Heavy duty hand operated hamburger press
- Made from highly polished satin finished anodised aluminium and stainless steel
- Available in 3 models: 100mm, 130mm and 150mm
- Container for cellophane separators
- Lever operation allows control of compression and extraction of finished patty
- Easy to clean with minimal servicing required



ACCESSORIES	PRODUCT CODE
100mm (4") Cellophane Discs (1kg pack)	BP9000330
130mm (5") Cellophane Discs (1kg pack)	BP9000331
150mm (6") Cellophane Discs (1kg pack)	BP9000329

MODEL	PRODUCT CODE	PATTY SIZE (mm)	CLOSED DIMENSIONS D x W x H (mm)	OPEN DIMENSIONS D x W x H (mm)	NET WEIGHT (kgs)
BP4	5BP4	100	255 x 235 x 240	255 x 305 x 310	4.6
BP5	5BP5	130	270 x 235 x 240	270 x 320 x 310	4.8
BP6	5BP6	150	280 x 235 x 240	280 x 330 x 310	5



CATALOGUE PAGE NO	PRODUCT NAME	PRODUCT CODE	PRICE
<b>SLICERS</b>			
5	NSL220	5S530N	£565
5	NSL250	5S531N	£625
6	NS220	5S503N	£665
6	NS250	5S252N	£685
6	NS300	5S302N	£990
7	NS250HD	5S251N	£895
7	NS300HD	5S301N	£1,575
7	NS350HD	5S510N	£1,795
8	NS300XHD	5S511N	£1,750
8	NS350XHD	5S512N	£1,895
8	NS370XHD	5S513N	£2,850
9	NS300A	5S514N	£3,550
9	NS350A	5S515N	£4,575
9	NS350AG	5S516N	£4,975
10	NSV250	5S517N	£1,045
10	NSV300	5S518N	£1,295
10	NSV350	5S519N	£2,375
11	NSV300HD	5S520N	£1,875
11	NSV350HD	5S521N	£2,475
<b>SLICER ACCESSORIES</b>			
12	Tray Extension Device (NS220/NS250/NS300/NS250HD)		£55
12	Tray Extension Device (NS300HD/NS350HD/NS300XHD/NS350XHD)		£60
12	Special Stainless Steel Handgrip		£195
12	Stainless Steel Knife Remover		£115
12	Stainless Steel Guard		£75
12	Teflon Coated Parts (all 220-350 models)		£215
12	Teflon Coated Parts (all 370 models)		£255

CATALOGUE PAGE NO	PRODUCT NAME	PRODUCT CODE	PRICE
SLICER ACCESSORIES CONTINUED			
12	Aluminium Knobs Kit		£205
12	Product Hold Bar for Gravity Plate		£115
12	Special Arm (Protected)		£340
12	Plastic Cover – small		£50
12	Plastic Cover – medium		£55
12	Serrated Blade		from £95
12	Slice Counter (for NS350A/NS350AG)		£400
12	Painting Customisation		£195
12	Plastic Knife Remover (all 250/300/350 Models)		£80
12	Vegetable Tube (for NS300A/NS350A/NS350AG)		£540
RETRO SLICERS			
14	RET300	5S506N	£3,875
14	RET330	5S522N	£6,275
15	RET370	5S523N	£7,475
15	RET370 AUTO	5S524N	£14,500
RETRO SLICER ACCESSORIES			
15	Cast Iron Pedestal with Round Base	5S507N	£1,400
15	Painting Customisation		£220
STICK BLENDERS			
16	Rapimix 200	5SB8220	£210
16	Rapimix 400	5SB8209	£565
16	Rapimix 500	5SB8210	£625
MIXERS			
17	SM5	5M237	£375
17	SM7	5M238	£395
22	MP7	5MP7	£795
22	MP9	5MP9	£990
23	MPI0	5MPI0	£1,595
24	MP20	5MP20	£2,075
26	MP30	5MP30-IPH	£3,275
26	MP30 3PH	5MP30-3PH	£3,275
26	MP40	5MP40-IPH	£4,575
26	MP40 3PH	5MP40-3PH	£4,575
26	MP60	5MP60-IPH	£7,450
26	MP60 3 PH	5MP60-3PH	£7,450

CATALOGUE PAGE NO	PRODUCT NAME	PRODUCT CODE	PRICE
MIXER ACCESSORIES			
17	SM5 Bowl	SM5/50401040F	£60
17	SM7 Bowl	SM7/50401038F	£65
17	SM5 & SM7 Beater	SM57/40201200F	£20
17	SM5 & SM7 Dough Hook	SM57/40201300F	£20
17	SM5 & SM7 Whisk	SM57/40202400F	£25
23	MP7 Bowl	MP11007-12-001	£105
23	MP7 Beater	MP11007-12-002	£60
23	MP7 Dough Hook	MP11007-12-003	£60
23	MP7 Whisk	MP11007-12-004	£65
23	MP9 Bowl	MPD10-12-001	£70
23	MP9 Beater	MPD10-12-002	£70
23	MP9 Dough Hook	MPD10-12-003	£70
23	MP9 Whisk	MPD10-12-004	£75
23	MP10 Bowl	MPBM10-12-001	£220
23	MP10 Beater	MPBM10-12-002	£105
23	MP10 Dough Hook	MPBM10-12-003A	£105
23	MP10 Whisk	MPBM10-12-004	£160
25	MP20 Bowl	MP11012-12-001	£245
25	MP20 Beater	MP11012-12-002	£160
25	MP20 Dough Hook	MP11012-12-003A	£160
25	MP20 Whisk	MP11012-12-004	£200
25	MP20 Floor Stand	5MP21	£220
25	MP20 Trolley	5MP22	£255
25	MP20 10ltr Reduction Bowl	MP11012-12-005	£135
25	MP20 10ltr Reduction Beater	MP11012-12-006	£85
25	MP20 10ltr Reduction Dough Hook	MP11012-12-007	£85
25	MP20 10ltr Reduction Whisk	MP11012-12-008	£100
25 & 27	Veg Prep Attachment (no plates)	MPVS12A	£610
25 & 27	3mm Slicing Plate	MPVS12-013A-3MM	£55
25 & 27	5mm Slicing Plate	MPVS12-013A-5MM	£55
25 & 27	1.5mm Shredding Disc	MPVS12-014A-1.5MM	£55
25 & 27	2mm Shredding Disc	MPVS12-014A-2MM	£55
25 & 27	3mm Shredding Disc	MPVS12-014A-3MM	£55
25 & 27	5mm Shredding Disc	MPVS12-014A-5MM	£55
25 & 27	6mm Shredding Disc	MPVS12-014A-6MM	£55

CATALOGUE PAGE NO	PRODUCT NAME	PRODUCT CODE	PRICE
MIXER ACCESSORIES CONTINUED			
25 & 27	8mm Shredding Disc	MPVS12-014A-8MM	£55
25 & 27	9mm Shredding Disc	MPVS12-014A-9MM	£55
25 & 27	Grater Disc	MPVS12-014A-GRATER	£55
25 & 27	Meat Mincer Attachment (6 & 8 mm extrusion plates included)	MPG12SH	£405
27	MP30 Bowl	MPI1031-12-001	£460
27	MP30 Beater	MPI1031-12-002	£210
27	MP30 Dough Hook	MPI1031-12-003	£210
27	MP30 Whisk	MPI1031-12-004	£230
27	MP30 Bowl Trolley	MPI1031-12-005	£250
27	MP30 20ltr Reduction Bowl	MPI1031-12-001M	£290
27	MP30 20ltr Reduction Beater	MPI1031-12-002M	£110
27	MP30 20ltr Reduction Dough Hook	MPI1031-12-003M	£110
27	MP30 20ltr Reduction Whisk	MPI1031-12-004M	£145
27	MP40 Bowl	MPI1040-12-001	£515
27	MP40 Beater	MPI1040-12-002	£245
27	MP40 Dough Hook	MPI1040-12-003	£245
27	MP40 Whisk	MPI1040-12-004	£290
27	MP40 Bowl Trolley	MPI1040-12-011	£250
27	MP40 20ltr Reduction Bowl	MPI1040-12-001M	£445
27	MP40 20ltr Reduction Beater	MPI1040-12-002M	£135
27	MP40 20ltr Reduction Dough Hook	MPI1040-12-003M	£135
27	MP40 20ltr Reduction Whisk	MPI1040-12-004M	£185
27	MP60 Bowl	MPI1091-12-008	£595
27	MP60 Beater	MPI1091-12-001	£315
27	MP60 Dough Hook	MPI1091-12-003	£315
27	MP60 Whisk	MPI1091-12-002	£350
27	MP60 Bowl Trolley	MPI1091-12-011	£255
27	MP60 30ltr Reduction Bowl	MPI1091-12-007	£495
27	MP60 30ltr Reduction Beater	MPI1091-12-004	£195
27	MP60 30ltr Reduction Dough Hook	MPI1091-12-006	£195
27	MP60 30ltr Reduction Whisk	MPI1091-12-005	£270
PASTA MACHINES			
28	TR50	5TR50	£1,375
28	TR70	5TR70	£2,225
28	TR75	5TR75	£4,475



CATALOGUE PAGE NO	PRODUCT NAME	PRODUCT CODE	PRICE
<b>PASTA MACHINE ACCESSORIES</b>			
29	Cutting Assembly for TR50	LPC01	£370
29	Cutting Assembly for TR70	LPC02	£470
29	Stainless Steel Cart with 5 Trays	LPC03	£875
29	Trolley for TR75	LPT01	£300
29	Plastic Pasta Tray	LPT02	£50
30	TR50 Brass Pasta Dies		£75
30	TR50 Teflon Pasta Dies		£95
30	TR50 Adjustable Sheet Pasta Die		£95
30	TR70 Brass Pasta Dies		£110
30	TR70 Teflon Pasta Dies		£130
30	TR70 Adjustable Sheet Pasta Die		£160
30	TR75 Brass Pasta Dies		£130
30	TR75 Teflon Pasta Dies		£150
30	TR75 Adjustable Sheet Pasta Die		£170
<b>BENCH MOUNTED POTATO PEELERS</b>			
32	EPI0 Bench Mounted Peeler	5PI01	£1,100
32	NAI0 Bench Mounted Peeler	5PI03	£1,200
32	EPI5 Bench Mounted Peeler	5PI51	£1,375
32	NAI5 Bench Mounted Peeler	5PI53	£1,450
<b>BENCH MOUNTED POTATO PEELER ACCESSORIES</b>			
33	Guarded Discharge Chute, Painted	9TI9	£65
33	Guarded Discharge Chute, S/S	9T24	£75
33	Type 'AA' Air Gap Tundish	9T25	£40
33	Small External Interceptor	9T22	£150
33	Small Waste Disposal Adaptor	9TI7	£105
33	Peeler Mobile Trolley	9T21	£245
33	Peeler Pedestal	9T20	£220
33	Sink Skip	TS06	£70
33	Length of Waste Pipe, Elbow & Coupling	9TI8	£45
33	3ft Length Water Inlet Hose and Tap Connector	9P64	£30
33	Installation Kit	9T28	£125
<b>PEDESTAL POTATO PEELERS</b>			
34	GU4 Low Pedestal Peeler 1ph	5PI45	£2,075
34	GU4 Low Pedestal Peeler 3ph	5PI46	£2,225
34	GU4 High Pedestal Peeler 1ph	5PI47	£2,125

CATALOGUE PAGE NO	PRODUCT NAME	PRODUCT CODE	PRICE
PEDESTAL POTATO PEELERS CONTINUED			
34	GU4 High Pedestal Peeler 3ph	5P148	£2,250
34	GU8 Low Pedestal Peeler 1ph	5P285	£2,525
34	GU8 Low Pedestal Peeler 3ph	5P286	£2,650
34	GU8 High Pedestal Peeler 1ph	5P287	£2,550
34	GU8 High Pedestal Peeler 3ph	5P288	£2,700
PEDESTAL POTATO PEELER ACCESSORIES			
35	Guarded Discharge Chute, Painted for GU4	9P59	£65
35	Guarded Discharge Chute, Painted for GU8	9P60	£75
35	Type 'AA' Air Gap Tundish	9T25	£40
35	3ft Length Water Inlet Hose and Tap Connector	9P64	£30
35	Waste Disposal Adaptor	9P57	£115
	Stainless Steel Waste Disposal Adaptor	9P82	£240
35	Large External Interceptor	9P27	£230
HAND POTATO CHIPPER			
36	HPC Detachable Block Chipper (Chassis Only)	5HC10	£270
HAND POTATO CHIPPER ACCESSORIES			
36	Set of Block, Knives & Frame for 8mm	9HC21	£140
36	Set of Block, Knives & Frame for 10mm	9HC22	£140
36	Set of Block, Knives & Frame for 12.5mm	9HC23	£140
36	Set of Block, Knives & Frame for 14mm	9HC31	£140
36	Set of Block, Knives & Frame for Wedger	9HC17	£140
36	Bench Mounting Stand	5HC07	£135
36	Floor Mounting Stand	5HC04	£225
ELECTRIC CHIPPER			
37	EC20 Electric Chipper (knife assembly not included)	5EC22	£2,600
ELECTRIC CHIPPER ACCESSORIES			
37	10mm Knife Assembly	9ECM01	£305
37	12mm Knife Assembly	9ECM02	£305
37	14mm Knife Assembly	9ECM03	£305
37	16mm Knife Assembly	9ECM04	£305
37	Floor Stand	5EC24	£215
37	Floor Trolley	5EC25	£250
GRATERS			
38	GMR - Retro Cheese Grater	5GMR01	£350
38	GSD - Cheese Grater	5GSD01	£625

CATALOGUE PAGE NO	PRODUCT NAME	PRODUCT CODE	PRICE
GRATERS CONTINUED			
39	TMC - Mozzarella Cheese Grater	5TMC102	£725
GRATER ACCESSORIES			
39	TMC Cone 1 - 2mm Holes	FM2282	£85
39	TMC Cone 2 - 2.5mm Holes	FM2280	£85
39	TMC Cone 3 - 4mm Holes	FM2281	£85
39	TMC Cone 4 - 7mm Holes	FM2182	£85
MINCERS			
40	TS12R - Retro Meat Mincer	5MMTS12R	£860
40	TS22 - Meat Mincer	5MMTS22	£875
41	Ti22R - Meat Mincer	5MMSTC22	£1,350
41	Ti32R - Meat Mincer	5MMSTC32	£1,875
MINCER ACCESSORIES			
41	TS12R Extrusion Plate – 3mm	FM0407/3	£36
41	TS12R Extrusion Plate – 3.5mm	FM0405/3.5	£36
41	TS12R Extrusion Plate – 4.5mm	FM2131/4.5	£36
41	TS12R Extrusion Plate – 6mm	FM2131/6	£36
41	TS12R Extrusion Plate – 8mm	FM2131/8	£36
41	TS12R Knife	FM2130	£20
41	TS22/Ti22R Extrusion Plate – 3mm	FM0410/3	£47
41	TS22/Ti22R Extrusion Plate – 3.5mm	FM0411/3.5	£47
41	TS22/Ti22R Extrusion Plate – 4.5mm	FM2219/4.5	£42
41	TS22/Ti22R Extrusion Plate – 6mm	FM2219/6	£42
41	TS22/Ti22R Extrusion Plate – 8mm	FM2219/8	£42
41	TS22/Ti22R Knife	FM2218	£25
41	Ti32R Extrusion Plate – 3mm	FM0413/3	£62
41	Ti32R Extrusion Plate – 3.5mm	FM0414/3.5	£55
41	Ti32R Extrusion Plate – 4.5mm	FM0502/4.5	£52
41	Ti32R Extrusion Plate – 6mm	FM0502/6	£52
41	Ti32R Extrusion Plate – 8mm	FM0502/8	£52
41	Ti32R Knife	FM0503	£30
HAMBURGER PRESS			
41	BP4 - 100mm Burger Press	5BP4	£295
41	BP5 - 130mm Burger Press	5BP5	£315
41	BP6 - 150mm Burger Press	5BP6	£345

CATALOGUE PAGE NO	PRODUCT NAME	PRODUCT CODE	PRICE
HAMBURGER PRESS ACCESSORIES			
41	BP4 Cellophane Discs (100mm)	BP9000330	£58
41	BP5 Cellophane Discs (130mm)	BP9000331	£60
41	BP6 Cellophane Discs (150 mm)	BP9000329	£60